

## Data Sheet

## CR16 MANUAL SHADE WITH FASCIA

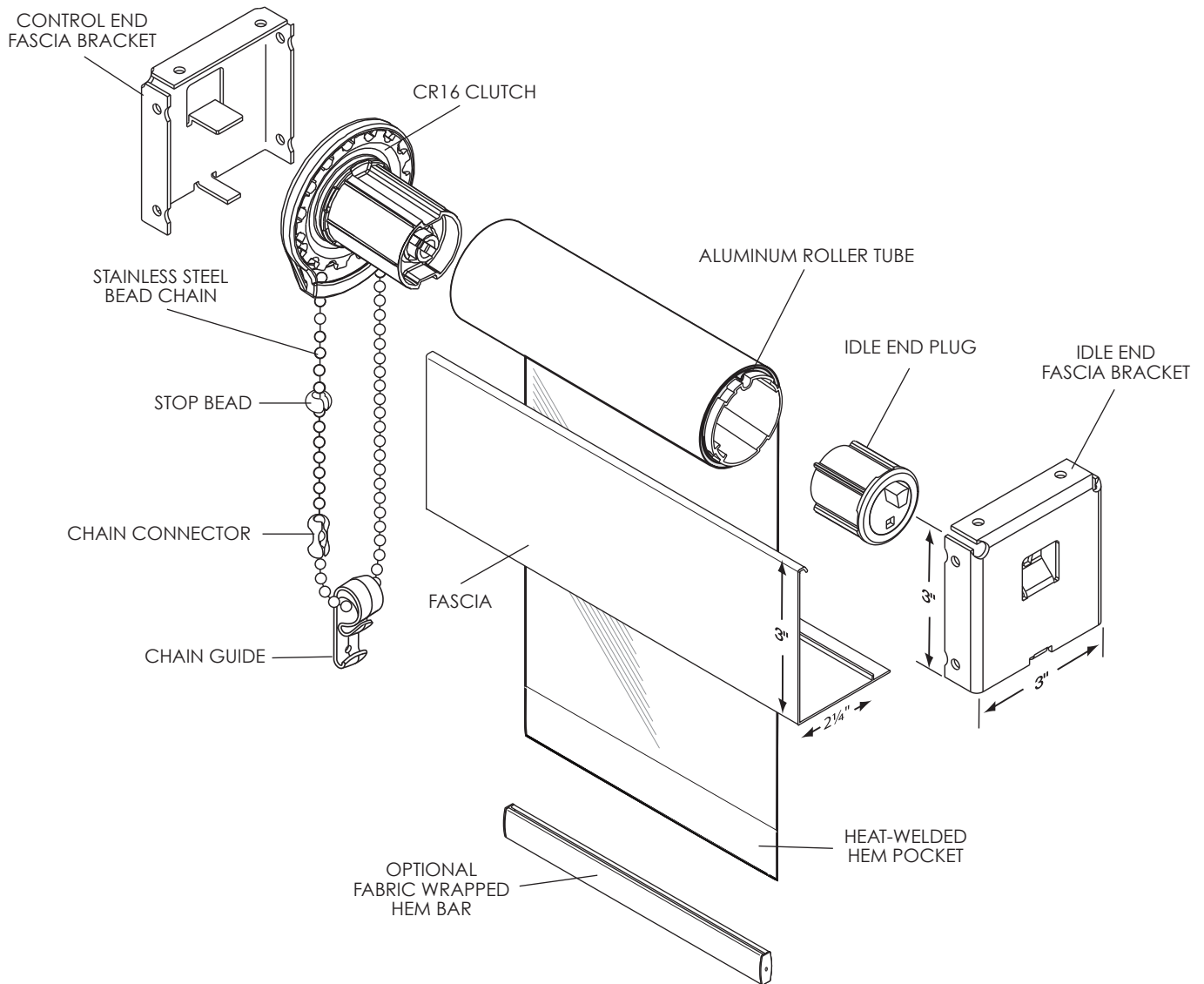

- CR16 clutch system is designed to lift shades weighing up to sixteen pounds.
- Shades are raised and lowered by means of a #10 stainless steel bead chain.
- Roller tube is extruded aluminum engineered with a channel to accept fabric spline making the shade panel easy to remove.
- The hem bar will be extruded aluminum and completely enclosed in a heat-welded hem pocket. Optional fabric wrapped hem bar.
- Edge gap is 5/8" on the clutch end and 5/8" on the idler end.
- Fascia measures 3" high with a 2-1/4" bottom lip and snaps onto 3" X 3" fascia bracket or 4" high with a 2-3/4" bottom lip and snaps onto a 4" X 4" fascia bracket. Available in white, vanilla, clear anodized, bronze or black.
- Optional lift assist reduces pull force allowing easy lifting of larger shades.